

Role of Emotional Content in Working Memory Capacity Evidence from Words and Faces

Yu Lan*

Nanjing Foreign Language School Xianlin Campus, Nanjing, China

*Corresponding author: 13875990882@163.com

Keywords: Sentiments, Memory ability, working memory capacity.

Abstract: Emotional events were generally considered to be better remembered than neutral events. Researches find that emotional content influences working memory capacity in either enhancement or impairment way. We employed an operation span (OSPAN) task with either words or emotional faces to investigate the effects of emotional content on working memory capacity. In a relatively small group of observers, emotional words showed no significant impairment on working memory capacity. When the emotional words and the neutral words were mixed to display, working memory capacity were significantly reduced while the accuracy of recalling in correct order were boosted. We further explored working memory capacity of the emotional faces using an OSPAN task. Although the facial emotion of each image was not required to be remembered, working memory capacity was reduced when encoding the emotional faces and recalling neutral faces compared with the condition that neutral faces for both encoding and recalling. This strong impairment effect might be caused by greater valence of emotional face images than emotional words. This impairment cannot be attributed to the failure of same identity recognition with different emotions. In an identity recognition task, different emotions of same identity showed a greater performance than the different identity recognition.

1. Introduction

Emotional events are better to be remembered than neutral events, while emotional states and stimuli may disturb the performance of memory. Many studies revealed that emotional stimuli are better recalled than neutral stimuli (Bradley, Greenwald, Petry, & Lang, 1992; Doerksen & Shimamura, 2001).

Emotional stimuli could capture attention and enhance stimulus processing, which leads to enhancement of memory representations and strengthens the memory during consolidation phase (Hamann, 2001; Vuilleumier, 2005). In Crowell's study, they found that higher trait approach motivation predicted better memory for the positive emotional stimuli but not the negative emotional stimuli, but this memory boost disappeared under cognitive load (Crowell & Schmeichel, 2016). On the other hand, some studies suggested that emotional states and emotional stimuli could interfere with cognitive processes, including working memory.

The automatic capture of attention by emotional content may impair cognitive processes relevant for memory. An emotional Stroop task discovered that emotional words could draw attention away from the task-relevant dimension of the stimulus (i.e., ink color) and to the distractor dimension (i.e., meaning of word). The interference increases the response time on this Stroop task (Williams, Mathews, & MacLeod, 1996). Emotional context was found to divert attention away from active memory maintenance and played a negative role in memory process (Schweizer & Dalgleish, 2016).

A number of previous studies investigated the effects of emotional information on working memory capacity (WMC). Working memory can be defined as the mental process to store and manipulate information in memory, even processing other information at the same time (Miyake & Shah, 1999). An operation span task (OSPAN) was used to examine the effects of emotional words relative to neutral words on WMC. An enhancement of WMC was revealed for emotional versus neutral words

using an OSPAN task (Mammarella, Borella, Carretti, Leonardi, & Fairfield, 2013). The emotional information could attract information and processing resources which led to an increased WMC. However, some other research has observed that WMC was impaired by the emotional content. In a study, participants were required to recall the last three words from a sequence of words, and WMC was impaired when the lists contained emotional versus neutral words (Fairfield, Mammarella, Di Domenico, & Palumbo, 2015).

Previous findings on the effects of emotional content on WMC is mixed. Both enhancement and impairment effect were observed in different studies. We wondered the role of emotional content played in the cognitive processes which underlies both working memory and executive attention control. In an OSPAN task, if the capture of attention by emotional information diverts processing resources away from the encoding or storage of items, the WMC of emotional word condition would be reduced. However, if the emotional content attracts attention and makes it easier to encode and store items, the WMC of emotional word would be increased. We tested both the emotional word condition and the neutral word condition, and added a mixed condition which consisted of one emotional word and one neutral word at intervals. The WMC among the neutral, emotional, and mixed conditions showed no significant difference. While using either PCU, ANU, or PCL scoring method, the WMC was significantly impaired in the mixed condition compared with the neutral condition. The accuracy of recalling the emotional word and the neutral word in the correct serial order was improved in the mixed condition rather than in emotional and neutral conditions respectively. The mixed display maybe disturbed the WMC but improved the precision of working memory storage. In a face OSPAN task, our results suggested that the emotional content could impair the WMC, though the emotion of each was task related. The attenuation of emotional content might boost the prevision of work memory.

2. Words OSPAN Tasks

2.1 Participants and design

Forty-one participants aged from seventeen to forty were recruited to participate (20 males and 21 females). Participants attempted a common working memory capacity test using the operation span task (OSPAN; Turner & Engle, 1989). The OSPAN task measures the ability of remembering a list of unrelated words while simultaneously solving mathematical operations. Participants were excluded if they scored below 85% accuracy on the mathematical operations. In this experiment, memory materials were displayed in three conditions: neutral words block, emotional words block and mixing emotional and neutral words condition. After exclusion based on the performance of math calculation, thirty-seven participants were included (fourteen males and nineteen females $14+19=33$).

2.2 Materials and procedure

Each paring of OSPAN task contained both the mathematical operation task and recall task, and the next paring was presented immediately after finishing the preceding paring. In each task, participants were required to first solve the simple mathematical proble and verify aloud whether the answers of operations were correct (e.g., “is $20 + 23*2 = 64$, correct? Yes or no). Then, read the simultaneously presented Chinese word aloud (e.g., “植物”, plant in Chinese) and try to remember it. At the end of each set, participants were asked to recall the Chinese words in correct order. In all, participants were presented 14 sets with a total of 56 words to be remembered in each OSPAN task. Set size ranged from two to five words parings. Data were collected from the recordings of participants.

There were three conditions of word display in this experiment with three lists of words: neutral words (e.g., “白纸”, paper in Chinese), emotional words which could either be positive or negative (e.g., “拥抱”, hug in Chinese and “蟒蛇”, python in Chinese), and mixed condition which contained both neutral words and emotional words. All selected words were evaluated by twenty participants measuring valence and arousal. Neutral words had a mean valence of 5.28 (SD = 0.31). Positive words

were high in valence (Mean = 7.61, SD = 0.5), whereas negative words were low in valence (Mean = 2.45, SD = 0.46).

We used four different scoring methods based on the procedure described by Conway et al. (2005), partial-credit unit scoring (PCU), all-or-nothing unit scoring (ANU), partial-credit load scoring (PCL), and all-or-nothing load scoring (ANL), to quantify participants' OSPAN tasks. More precisely, for unit loading, we counted the sum of all correct words recalled proportionally in their sets (partial-credit unit scoring), and we counted the sum of sets with all words recalled correctly (all-or-nothing unit scoring). For load scoring, we counted all the words correctly recalled in the experiment (partial-credit load scoring) and we calculated the sum of correctly recalled words from the set with all the words were recalled correctly (all-or-nothing load scoring).

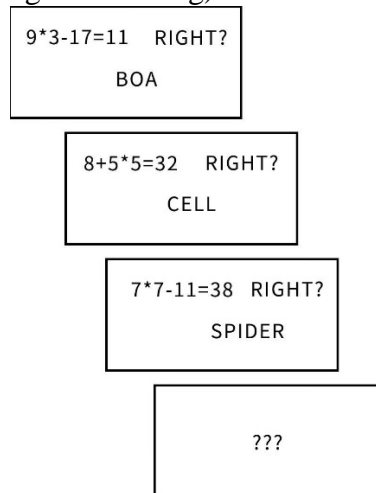

Figure 1. Trial structure of the operation span task in the emotional words condition.

3. Results

The behavioral performance of working memory was quantified by all four scoring methods as dependent measures: all-or-nothing load scores (ANL), all-or-nothing unit scores (ANU), partial-credit load scores (PCL), and partial-credit unit scores (PCU). We conducted one-way ANOVA test to the WMC of the neutral, emotional, and mixed conditions. None of the scoring methods showed significant difference between the neutral, emotional, and mixed conditions either total recall accuracy or recall accuracy in the correct serial order. However, we can observe a descending trend of WMC decreasing from neutral, to emotional and mixed conditions. The PCU, ANU, and PCL scoring methods showed a significant difference of WMC between the neutral and mixed conditions (PCU: neutral vs. mixed, $t_{(36)} = 2.04$, $p < 0.02$, Cohen's $d = 0.46$; ANU: neutral vs. mixed, $t_{(36)} = 1.84$, $p < 0.05$, Cohen's $d = 0.40$; PCL: $t_{(36)} = 2.07$, $p < 0.02$, Cohen's $d = 0.44$). We further analyzed the capacity and precision of emotion and neutral words in different conditions. The emotional words were recalled significantly less in mixed condition than they were recalled in emotional condition ($t_{(36)} = -2.72$, $p < 0.01$, Cohen's $d = -0.45$). The neutral words were also recalled significantly less in mixed condition than they were recalled in emotional condition ($t_{(36)} = -3.59$, $p < 0.001$, Cohen's $d = -0.59$). The working memory capacity of both emotional words and neutral words was reduced in the mixed condition. While the recall accuracy in the correct serial order for emotional words in mixed condition was significantly improved compared with it in emotional condition ($t_{(36)} = 3.768$, $p < 0.001$, Cohen's $d = 0.62$). We also found the enhancement of recall accuracy in the correct serial order for neutral words in mixed condition compared with it in neutral condition ($t_{(36)} = 5.55$, $p < 0.001$, Cohen's $d = 0.91$). In both the emotional and mixed condition, the recall accuracy of positive words was significantly lower than the negative words (emotional condition: $t_{(36)} = -7.07$, $p < 0.001$, Cohen's $d = -1.17$, mixed condition: $t_{(36)} = -7.07$, $p < 0.001$, Cohen's $d = -1.16$). The negative words were better remembered in the emotional condition rather than the mixed condition ($t_{(36)} = 3.11$, $p < 0.005$, Cohen's $d = 0.51$). While the positive words showed no such difference between emotional and mixed conditions.

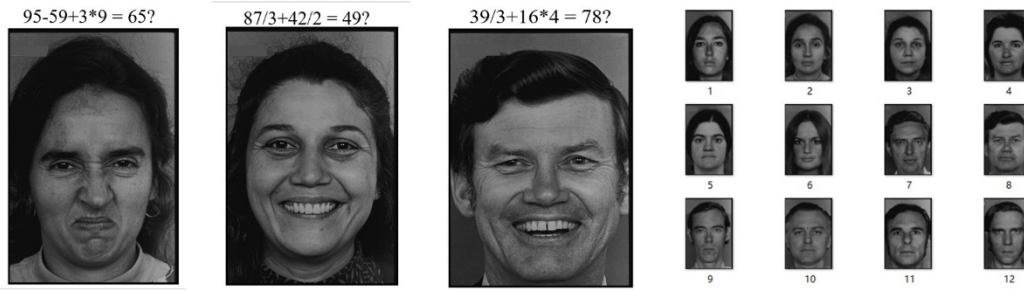

Figure 2. Trial structure of the emotional face condition.

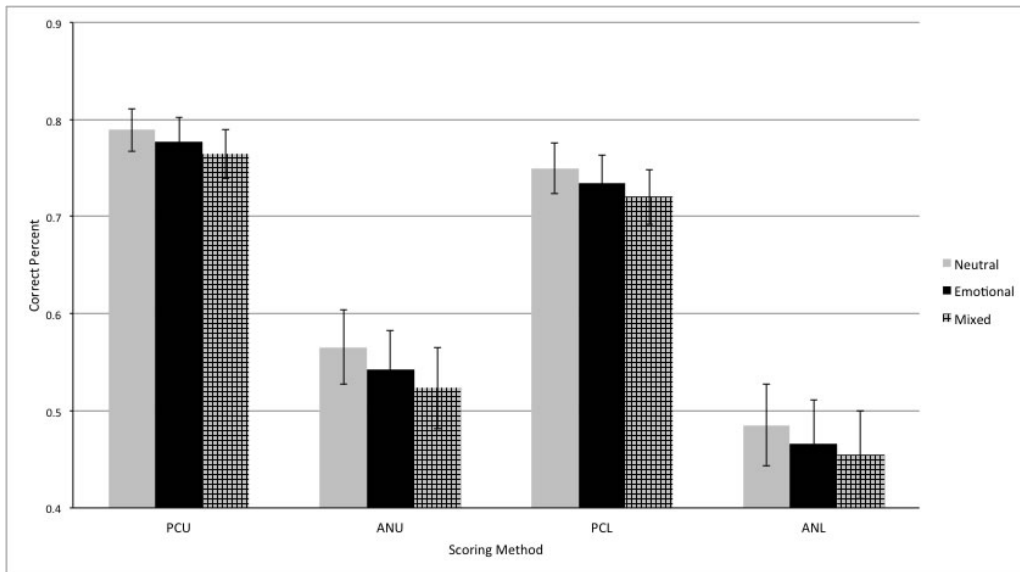

Figure 3. Results of words OSPAN task. Three conditions of neutral, emotional and mixed words were shown in different bars.

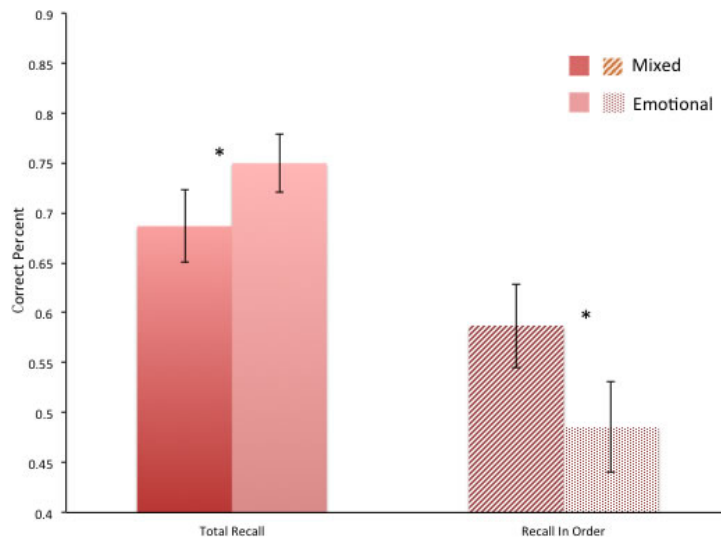

Figure 4. Left panels, behavioral performance of recalling accuracy for emotional words in mixed and emotional condition. Right panels, behavioral performance of recalling accuracy in correct order for emotional words in mixed and emotional condition.

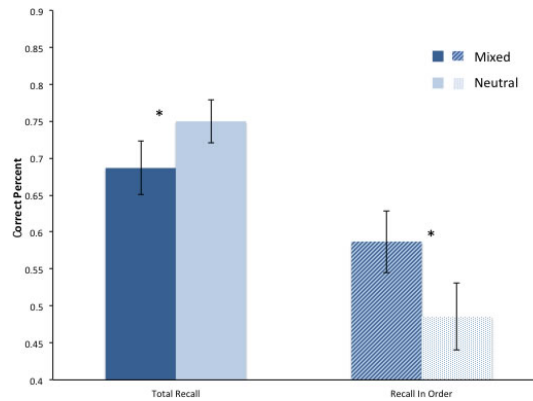

Figure 5. Left panels, behavioral performance of recalling accuracy for neutral words in mixed and neutral condition. Right panels, behavioral performance of recalling accuracy in correct order for neutral words in mixed and neutral condition.

4. Facial images OSPAN Tasks

4.1 Participants and design

Twelve participants aged from sixteen to thirty were recruited to participate (six males and six females). They were asked to conduct two conditions of facial images OSPAN tasks, which were different at the encoding phase. In the emotional faces condition, the facial image carrying either positive or negative emotion was displayed with the math problem and neutral faces were provided at the recalling phase, even though the facial emotion was not required to be remembered. In the neutral faces condition, at both the encoding and recalling phases, neutral faces were displayed. At the recalling phase, the subjects were provided with all the twelve neutral faces presented in the whole block and choose the number of the faces displayed in this set-in correct order.

Participants were excluded if they scored below 85% accuracy on the mathematical operations. After exclusion the final sample included eleven participants (5 males and 6 females).

5. Materials and procedure

Facial images were selected from the Ackman Picture System. A total of twelve faces with each having three different facial emotions, negative, positive and neutral, were selected as stimuli in this experiment. In these twelve faces, six faces were from males and six faces were from females. In neutral facial images OSPAN task, participants were required to solve the mathematical operations at first and verify aloud whether the answers of operations were correct (e.g., “is $28 + 33/3 = 37$, correct? Yes/no). Then, below each equation was a neutral face whose identity was required to be remembered. At the end of each set, participants were required to choose all faces appearing in the set from twelve neutral faces in correct order. In emotional facial images OSPAN task, following each mathematical operation was an emotional face which could be negative or positive. The emotion was not required to be remembered. At the end of each set, participants were required to choose all the identities appearing in the set from twelve neutral faces. In all, participants saw 12 sets with a total of 48 facial images to be recalled in each facial images OSPAN task. Data were collected through participants’ recordings. Four scoring were employed in this experiment: PCU, ANU, PCL, and ANL.

6. Results

In this experiment, the neutral condition showed a significantly greater behavioral performance of working memory capacity than the emotional condition, measured by the four-scoring method PCU, ANU, PCL, and ANL (PCU: $t_{(10)} = 4.36$, $P=0.001$, Cohen’s $d = 1.31$; ANU: $t_{(10)} = 5.30$, $P<0.001$, Cohen’s $d = 1.60$; PCL: $t_{(10)} = 4.05$, $P=0.002$, Cohen’s $d = 1.22$; ANL: $t_{(10)} = 6.30$, $P<0.001$, Cohen’s $d = 1.90$).

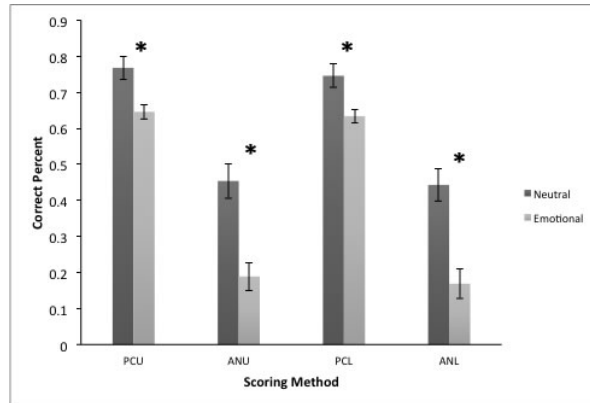

Figure 6. Results of the facial images OSPAN task.

7. Experiment 3 same identity recognition task

7.1 Participants and design

Twelve students aged from sixteen to eighteen were recruited from Nanjing Foreign Language School (6 males and 6 females). From experiment 2, working memory capacity for neutral facial images was much greater than that for emotional facial images. To test whether this result was due to difficulty in discriminating different emotions of same identity, we designed this control experiment. In this experiment, participants were given two images in two intervals, and then choose whether the two images were of the same identity. In the same identity condition, the images were one neutral face and one emotional face of the same person, while in the different identity condition, the images were of different persons with different emotion.

8. Materials and procedure

Same facial images as Experiment 2 were adopted in this experiment. In all, participants conducted 32 trials for each condition. The image was at the size of 5° and presented at the center of the screen. Each trial began with a 300ms central fixation. Then, the first facial image was displayed for 600ms. After a 300ms blank, the second facial image was presented for 600ms. Then participants were required to judge whether the two faces were from the same person and then made responses using arrow key (i.e., the right key or left key) on the keyboard.

9. Results

In this experiment, the accuracy of facial recognition for the same identity was significantly greater than that of the different identity ($t_{(11)} = 2.13, p < 0.05$, Cohen's $d = 0.63$). The same identity carrying different emotions was correctly recognized as the same person at a relatively high accuracy of 92%.

10. Discussion

The current study with words as memory materials did not show a significant impairment of WMC caused by the emotional words relative to neutral words. In the future, with a large group data we might be able to discover a significant difference between these three conditions. Also, the state of anxiety or depression of each subject should be measured to investigate whether this could lead to a different finding.

Surprisingly, our findings revealed that when the emotional and neutral words were mixed to display, the WMC was reduced, while the precision of the working memory defined as the accuracy of recalling in the correct order was improved. With emotional and neutral face images as memory materials, we found a significant impairment of WMC caused by the emotional content carried by the facial image, even though the emotion of the facial image was not required to be remembered. This

interference effect cannot contribute to the incapability of same identity recognition, which was tested to show a relatively greater performance. The facial emotion may have greater emotional valence than the emotional words, which were exposed much in our daily life. The processing of facial emotion is more automatic and faster, which was important in the ecological way.

We agree with the findings that emotional words receive prioritized (i.e., fast, automatic) processing relative to neutral words (Vuilleumier, 2005). However, in a working memory span task, the elaboration in a correct order is disturbed by the requirement of perform concurrent cognitive operations, which could impair the storage of emotional words even though they received prioritized processing initially. In words OSPAN task, in the mixed condition, less emotional words diluted the emotion valence, which could help to hold the memory of two different categories of words in a correct order but at the cost of sacrificing the capacity of working memory. On the other hand, in either the emotional or the neutral condition, words from the same category may confound the memory precision but improve the capacity. It's not only the emotional content but also the category of emotional content plays a role in the behavioral performance of working memory.

Our findings suggest that the emotional content in a facial image also receives a prioritized processing relative to neutral face. This could greatly impair the working memory capacity and precision. In the future, other dimension of facial image such as attractiveness could be explored to test whether it influences behavioral performance of working memory.

References

- [1] Bradley, M. M., Greenwald, M. K., Petry, M. C., & Lang, P. J. (1992). Remembering pictures: Pleasure and arousal in memory. *Journal of Experimental Psychology: Learning, Memory, and Cognition*, 18, 379–390.
- [2] Crowell, A., & Schmeichel, B. J. (2016). Approach motivation and cognitive resources combine to influence memory for positive emotional stimuli. *Cognition and Emotion*, 30, 389–397.
- [3] Doerksen, S., & Shimamura, A. P. (2001). Source memory enhancement for emotional words. *Emotion*, 1, 5–11.
- [4] Fairfield, B., Mammarella, N., Di Domenico, A., & Palumbo, R. (2015). Running with emotion: When affective content hampers working memory performance. *International Journal of Psychology*, 50, 161–164.
- [5] Hamann, S. (2001). Cognitive and neural mechanisms of emotional memory. *Trends in Cognitive Sciences*, 5, 394–400.
- [6] Mammarella, N., Borella, E., Carretti, B., Leonardi, G., & Fairfield, B. (2013). Examining an emotion enhancement effect in working memory: Evidence from age-related differences. *Neuropsychological Rehabilitation*, 23, 416–428.
- [7] Miyake, A., & Shah, P. (1999). *Models of working memory*. Cambridge, UK: Cambridge University Press.
- [8] Schweizer, S., & Dalgleish, T. (2016). The impact of affective contexts on working memory capacity in healthy populations and in individuals with PTSD. *Emotion*, 16, 16–23.
- [9] Turner, M. L., & Engle, R. W. (1989). Is working memory capacity task dependent? *Journal of Memory and Language*, 28, 127–154.
- [10] Vuilleumier, P. (2005). How brains beware: Neural mechanisms of emotional attention. *Trends in Cognitive Sciences*, 9, 585–594.
- [11] Williams, J. M. G., Mathews, A., & MacLeod, C. (1996). The emotional Stroop task and psychopathology. *Psychological Bulletin*, 120, 3–24.